

TIRANTE  
EYEBOLT

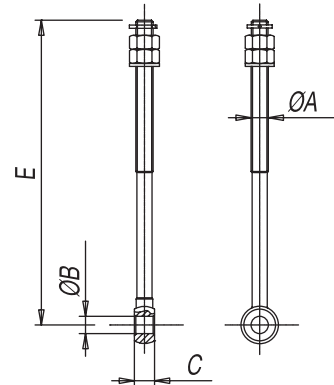

TIPO TYPE	Ø FUNE ROPE Ø	E	CODICE ASSIEME COMPLETE CODE	ØA	ØB	C	E	DADO SCREW	RONDELLA WASHER	COPIGLIA SPLIT PIN	CODICE CODE
CF1	6-8	175	8024512170	M12	12	14	175	M12	Ø12	3x35	8000812170
		300	8024512300				8000812300				
		400	8024512400				8000812400				
		500	8024512500				8000812500				
CF2	9-11	300	8024516300	M16	16	17	300	M16	Ø16	3x35	8000816300
		340	8024516350				8000816340				
		400	8024516400				8000816400				
		500	8024516500				8000816500				
CF3	12-14	300	8024520300	M20	18	22	300	M20	Ø20	3x35	8000820300
		350	8024520350				8000820350				
		400	8024520400				8000820400				
		500	8024520500				8000820500				
CF4	15-16	300	8024524300	M24	22	25	300	M24	Ø24	4x40	8000824300
		350	8024524350				8000824350				
		400	8024524400				8000824400				
		500	8024524500				8000824500				
CF5	4-5	200	8024510200	M10	10	12	200	M10	Ø10	3x20	8000810200
		250	8024510250				8000810250				
		300	8024510300				8000810300				
		400	8024510400				8000810400				
CF6	6-6,5	200	8024511200	M10	10	10	200	M10	Ø10	3x20	8000810200
		250	8024511250				8000810250				
		300	8024511300				8000810300				
		400	8024511400				8000810400				

\* PER RICHIEDERE LA FORNITURA DELL'ASSIEME CON LA SOLA CUSTODIA ZINCATA SOSTITUIRE L'ULTIMA CIFRA DEL CODICE (0) CON (1).

\* PER RICHIEDERE LA FORNITURA DELL'ASSIEME ZINCATO SOSTITUIRE L'ULTIMA CIFRA DEL CODICE (0) CON (5).

\* PER RICHIEDERE LA FORNITURA DEI SINGOLI PEZZI ZINCATI SOSTITUIRE L'ULTIMA CIFRA DEL CODICE (0) CON (1).

\* TO REQUEST THE SUPPLYING OF ROPE ANCHORAGES WITH HOLDER GALVANIZED CHANGE LAST NUMBER OF CODE (0) WITH (1).

\* TO REQUEST THE SUPPLYING OF ROPE ANCHORAGES COMPLETELY GALVANIZED CHANGE LAST NUMBER OF CODE (0) WITH (5).

\* TO REQUEST THE SUPPLYING OF EVERY SEPARATE COMPONENT GALVANIZED CHANGE LAST NUMBER OF CODE (0) WITH (1).



COMPONENTI MECCANICI  
PER ASCENSORI

MECHANICAL LIFT  
COMPONENTS

CAPIFUNDE SENZA MOLLA  
ROPE ANCHORAGES WITHOUT SPRING

T-245

CUNEO  
WEDGE

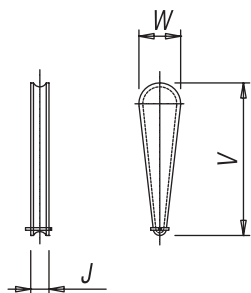

SPINA  
PARALLEL PIN

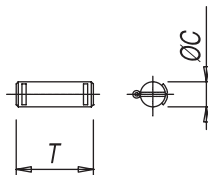

CUSTODIA  
HOLDER

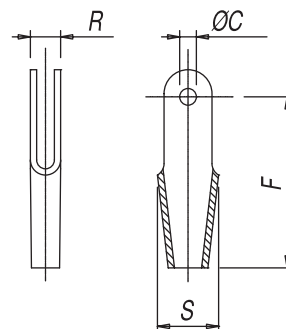

TIPO TYPE	J	V	W	COPIGLIA SPLIT PIN	CODICE CODE	ØC	T	COPIGLIA SPLIT PIN	CODICE CODE	ØC	F	R	S	CODICE CODE
CF1	11	92	25	3x35	8000600010	12	35	3x35	8000610010	12	130	22	45	8000700010
CF2	14	117	32	3x35	8000600020	16	42	3x35	8000610020	16	164	29	59	8000700020
CF3	18	141	38	3x35	8000600030	18	52	3x35	8000610030	18	198	38	72	8000700030
CF4	21	162	46	3x35	8000600040	22	60	4x40	8000610040	22	224	45	87	8000700040
CF5	9	68	19	1,5x20	8000600050	10	26	1,5x20	8000610050	10	96	18	31	8000700050
CF6	8	58	18	1,5x20	8000600060	10	26	1,5x20	8000610060	10	85	18	35	8000700060

\* PER RICHIEDERE LA FORNITURA DELL'ASSIEME CON LA SOLA CUSTODIA ZINCATA SOSTITUIRE L'ULTIMA CIFRA DEL CODICE (0) CON (1).

\* PER RICHIEDERE LA FORNITURA DELL'ASSIEME ZINCATO SOSTITUIRE L'ULTIMA CIFRA DEL CODICE (0) CON (5).

\* PER RICHIEDERE LA FORNITURA DEI SINGOLI PEZZI ZINCATI SOSTITUIRE L'ULTIMA CIFRA DEL CODICE (0) CON (1).

\* TO REQUEST THE SUPPLYING OF ROPE ANCHORAGES WITH HOLDER GALVANIZED CHANGE LAST NUMBER OF CODE (0) WITH (1).

\* TO REQUEST THE SUPPLYING OF ROPE ANCHORAGES COMPLETELY GALVANIZED CHANGE LAST NUMBER OF CODE (0) WITH (5).

\* TO REQUEST THE SUPPLYING OF EVERY SEPARATE COMPONENT GALVANIZED CHANGE LAST NUMBER OF CODE (0) WITH (1).